

# JOIN THE REDI-FLANGE™ CONNECTION

No Welding...  
No Threading...  
No Grooving!

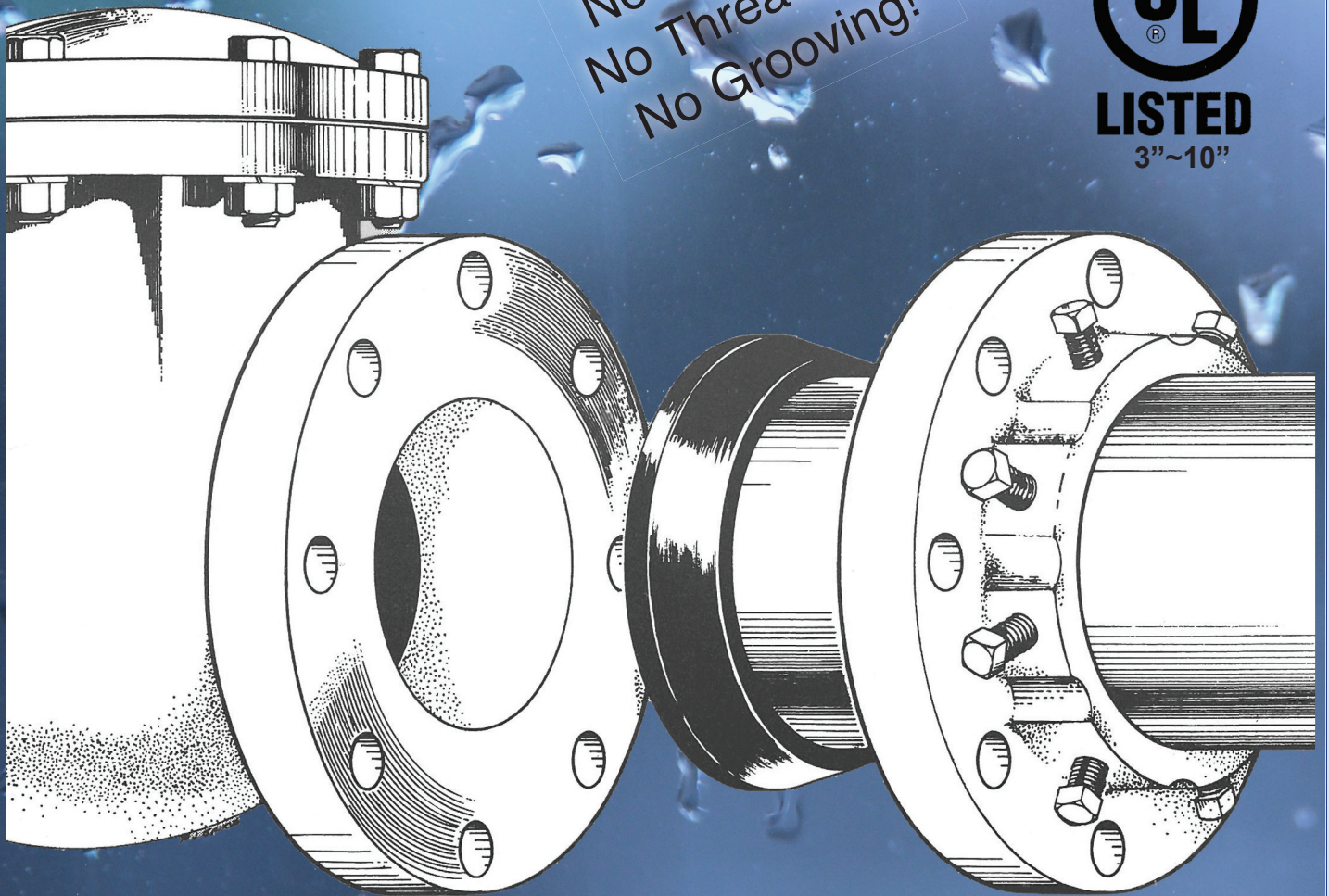

**UNITED** Water Products

## The Redi-Flange™ Method

“Redi-Flange™” is a method of joining valves, fittings and equipment with integral flanged ends to plain-ended pipe, with all the advantages of welded, grooved and screwed systems, but without the need for pipe end preparation.

## How It Works

Like all the best ideas, the working principle of Redi-Flange™ is a simple one. Slide the flange over plain-ended pipe and follow it with the standard mechanical joint type gasket. When the Redi-Flange™ is brought to mate against the existing flange, and the flange bolts are tightened, it creates a compression seal against the mating flange and down on the pipe surface. No additional gasket is needed.

End restraint is provided when the set screws are tightened.

## Services

The same people who sell Redi-Flange™ products are eager to offer prompt, professional service. Our policy is to seek long term business relationships with our customers, based upon manufacturing and delivering superior products and services on time, every time. Your satisfaction is guaranteed.

## Engineering & Costing Assistance

Redi-Flange™ engineers are available to help you design and cost-out your new projects using Redi-Flange™ products. Take advantage of our expertise to help you choose gasket materials to meet your particular requirements.

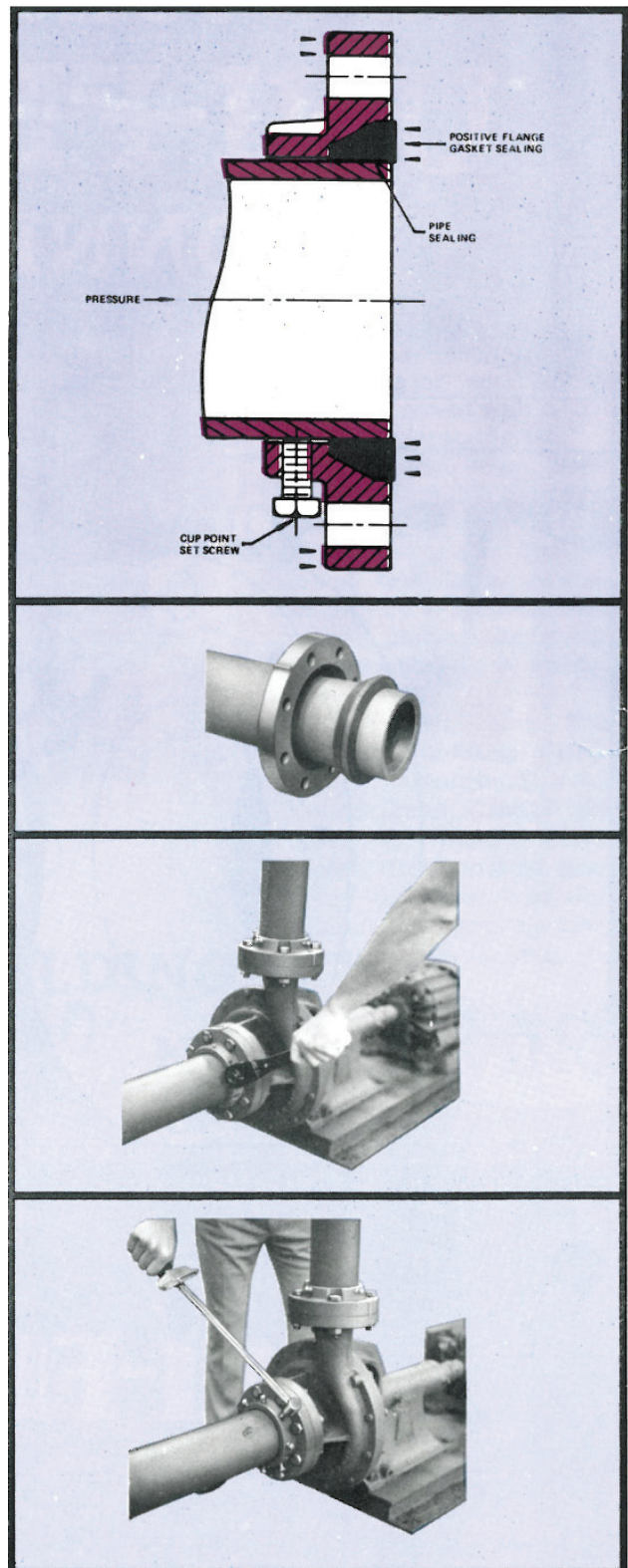

## Redi-Flange™ Advantages

Job site fabrication, using plain end pipe:

Redi-Flange™ eliminates the problems of pre-engineered, prefabricated piping systems. For a start, pipe sizing need not be so precise, because lengths can be cut and can be made up to suit site requirements. Mistakes in fabrication or drawings can be easily rectified on-site, instead of relying on off-site supplied, machinists and fabricators. DOWN TIME SAVINGS are considerable.

Plain-end pipe is considerably cheaper than threaded or flanged pipe - Redi-Flange™ makes is easy to use (and use some cut-offs too).

Redi-Flange™ has built-in end restraint. No tie rods, no anchoring, no fixing (have you looked at the

price of tie rods lately?).

Redi-Flange™ allows a deflection flexibility setting, and an improved cutting - tolerance.

When installing the pipe, misalignment can often be allowed for by using the deflection setting incorporated in the design of Redi-Flange™. There is an allowance of 1/2" between pipe and mating flange, which allows for a lower degree of accuracy than would be necessary with rigid flanged systems.

Redi-Flange™ needs no special plant or equipment for installation.

No threading, grooving or welding equipment, for instance.

Fast, easy installation with out skilled labor.

If you can use a wrench, you can use Redi-Flange™.

Eliminates bolt hole alignment problems.

Redi-Flange™ can be freely rotated before bolt tightening, enabling easy bolt hole alignment.

Eliminates additional restraining connections.

Redi-Flange™ makes life easier on site, where it matters.

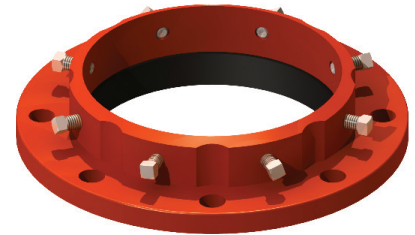

# Redi-Flange In Action

## **Will the set screws damage the pipe?**

With ductile or steel pipe, which the Series 400 was designed for, there is no danger of pipe damage due to the high tensile strength of this material.

The set screws are cup point and divide the stress evenly around the o.d. of the pipe, minimizing the possibility of damage.

The principle of set screws for pipe restraint is not an entirely new idea having been developed nearly fifty years ago, and used in hundreds of thousands of mechanical type joint retainer glands, with totally satisfactory results throughout the world.

## **Will the set screws "back-out" or loosen with continual use?**

When the set screw is originally tightened, it creates a "pocket" in the pipe. Even if the set screw loosens, it will remain inside this pocket and continue to restrain the flange.

## **Will the set screws hold on a high vibration connection like a pump?**

In practice no problems have been reported under these conditions, but for added security we recommend either:

A. Wiring of set screws to prevent loosening.

B. Using lock-nuts, or a product like "Loc-Tite".

## **Will the Redi-Flange™ work on PVC pipe?**

Yes, it will but it is not recommended. Over a period of time set screws can cause disfiguring of the pipe, affecting the seal.

## **Can Redi-Flange™ be used underground and above ground?**

Yes, both. All materials are corrosion resistant.

## **How far off can the length of pipe be? How exact is the cutting tolerance?**

The pipe should not exceed 1/4" back from the mating flange thereby giving an improved cutting tolerance over rigid, screwed or welded flanges.

## **Can Redi-Flange™ be used face to face?**

Yes, with a metal ring/spacer.

## **Can Redi-Flange™ be used on steam or gas?**

It is excellent for gas because of its superior seal. It is not recommended for prolonged use on steam.

## **Can Redi-Flange™ be used on temperature applications?**

Yes, our various gaskets will handle most temperature ranges.

## **Can you put abrasive material through the Redi-Flange™?**

Yes, the flange itself is not in contact with the media. The gasket is synthetic rubber, which has good abrasion resistance. Also, the pipe may be installed with a metal to metal contact, completely protecting the gasket.

## **What about expansion/contraction?**

In common with other rigid systems, Redi-Flange™ does not allow for pipe expansion/contraction.

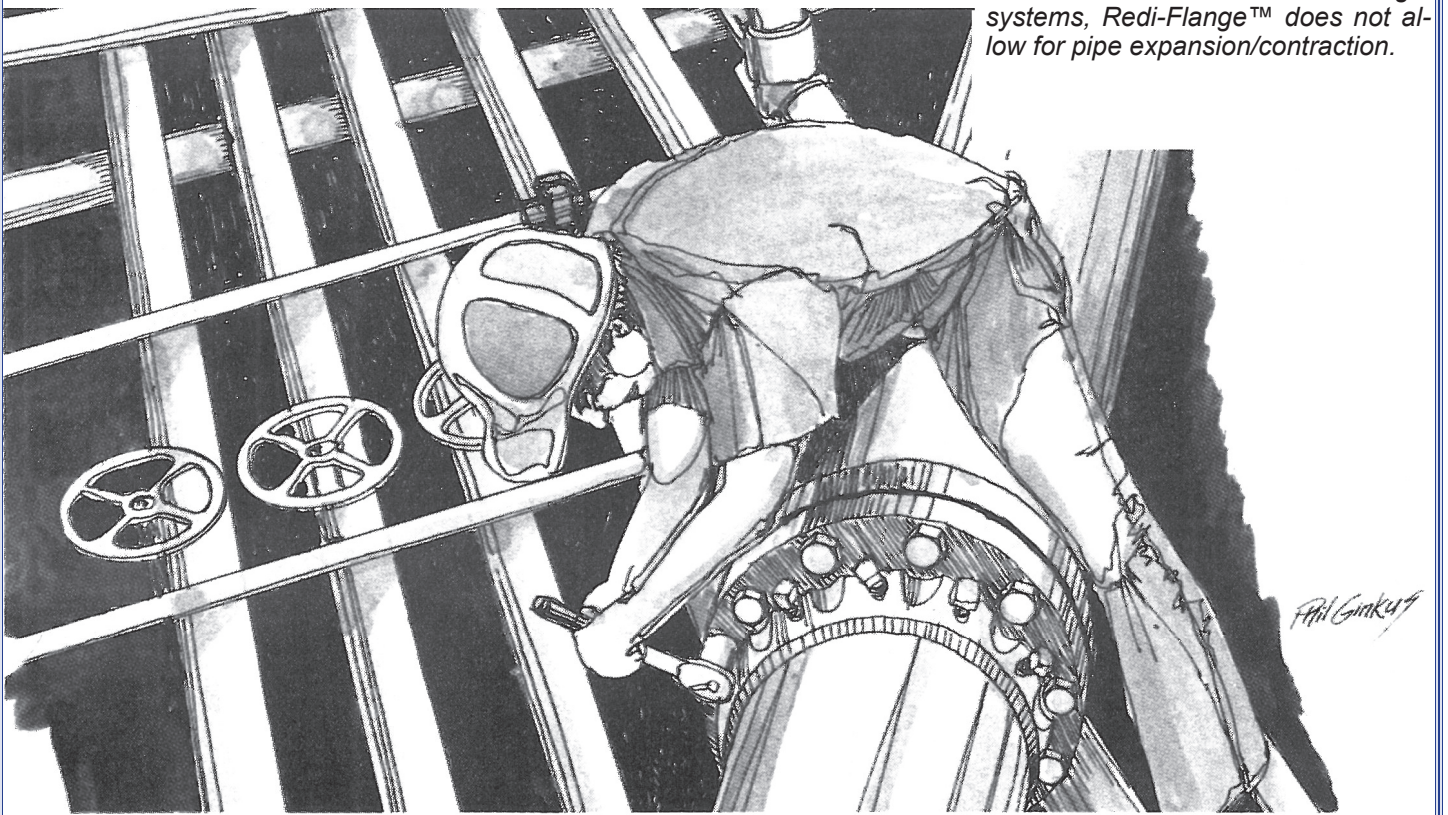

# Technical Data

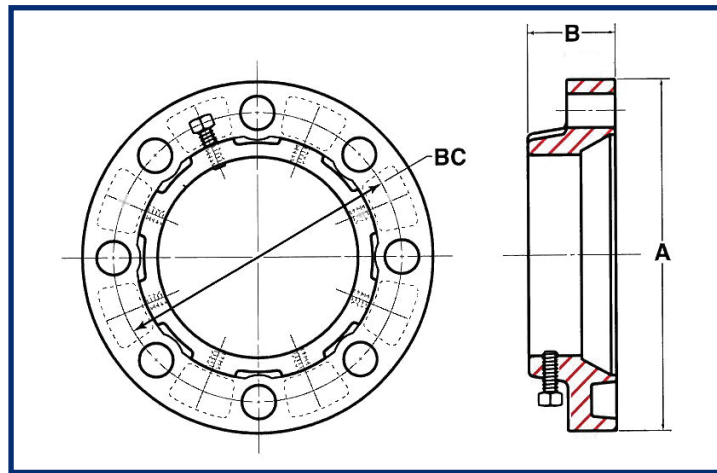

## STANDARDS:

Ductile Iron - ASTM A536

Grade 65-45-12.

Drilling to:

ANSI B16.1 - 125 lb.

ANSI B16.5 - 150 lb.

**SET SCREW:** AISI 4140 steel

Tensile 160,000 psi minimum

**GASKET:** SBR (BUNA-N).

## HYDROSTATIC TEST PRESSURE:

MODEL - RFC-2 - 125 lb./150 lb.

3 in. ~ 8 in. - 600 psi (UL rated 175 psi)

10 in. - 525 psi (UL rated 175 psi)

MODEL - RFC-4 - 125 lb./150 lb.

14 in. - 24 in. 450 psi

30 in. - 36 in. 300 psi

## Model RFC-2

Nom. Pipe Size	Part No.	D.I. Pipe O.D. RFC-2-D	Steel Pipe O.D. RFS-2-S	Flange O.D.	Bolt Circle	Bolt Hole Dia.	Set Screws		Wgt. Approx. (lbs)
							No.	Size	
*2"	RFC-201	2.50	2.38	6	4-3/4	3/4	2	1/2 x 1	3.5
*2-1/2"	RFC-202	-	2.88	7	5-1/2	3/4	4	1/2 x 1	4
*3"	RFC-203	3.96	3.50	7-1/2	6	3/4	4	1/2 x 1	5
*4"	RFC-204	4.80	4.50	9	7-1/2	3/4	4	1/2 x 1	8
*5"	RFC-205	-	5.56	10	8-1/2	7/8	8	1/2 x 1	9
*6"	RFC-206	6.90	6.625	11	9-1/2	7/8	8	1/2 x 1	10
*8"	RFC-208	9.05	8.625	13-1/2	11-3/4	7/8	8	5/8 x 1-1/4	17
*10"	RFC-210	11.10	10.75	16	14-1/4	1	12	5/8 x 1-1/4	22
*12"	RFC-212	13.20	12.75	19	17	1	12	5/8 x 1-1/4	31

Use Prefix RFC for DI Pipe - RFS for Steel Pipe

## Model RFC-4

Nom. Pipe Size	Part No.	D.I. Pipe O.D. RFC-4-D	Flange O.D.	Bolt Circle	Bolt Hole Dia.	Set Screws		Wgt. Approx. (lbs)
						No.	Size	
14"	RFC-414	15.30	21	18-3/4	1-1/8	12	5/8 x 1-1/4	70
16"	RFC-416	17.40	23-1/2	21-1/4	1-1/8	16	5/8 x 1-1/4	79
18"	RFC-418	19.50	25	22-3/4	1-1/4	16	3/4 x 2	90
20"	RFC-420	21.60	27-1/2	25	1-1/4	20	3/4 x 2	145
24"	RFC-424	25.80	32	29-1/2	1-3/8	20	3/4 x 2	175
30"	RFC-430	32.00	38-3/4	36"	1-3/8	28	1 x 2-1/4	270
36"	RFC-436	38.30	46	42-3/4	1-5/8	32	1 x 2-1/4	400

Dimensions in Inches



**WARNING:** This product can expose you to chemicals including lead, which is known to the State of California to cause cancer and birth defects or other reproductive harm. For more information go to [www.P65Warnings.ca.gov](http://www.P65Warnings.ca.gov).

# Deflection Chart

## Thrust Restraint

### Series RFC-4/RFC-2

**Deflection Chart**

Nom. Pipe Size	Ductile Iron Pipe O.D.	Steel Pipe O.D.	Maximum Angle Deflection	Deflection In/18 Ft. Lgth.
2"	2.50	2.375	4° ~ 2'	15.23
2-1/2"	-	2.875	3° ~ 56'	14.85
3"	3.96	3.50	3° ~ 50'	14.47
4"	4.80	4.50	3° ~ 44'	14.09
6"	6.90	6.625	3° ~ 36'	13.59
8"	9.06	8.625	3° ~ 20'	12.58
10"	11.10	10.75	3° ~ 13'	12.14
12"	13.20	12.75	2° ~ 35'	9.12
14"	15.30	14.00	2° ~ 20'	8.80
16"	17.40	16.00	2° ~ 5'	7.86
18"	19.50	18.00	2° ~ 0'	7.54
20"	21.60	20.00	1° ~ 56'	7.29
24"	25.80	24.00	1° ~ 37'	6.10

**Thrust Restraint (Series RFC-4)**

Nom. Pipe Size	WWP Rating (psi)	Thrust At Rated Pressure (lbs)	Thrust Restraint (lbs)
14"	150	23,091	75,900
16"	150	30,159	101,200
18"	150	38,170	110,400
20"	150	47,124	138,000
24"	150	67,858	138,000

**Thrust Restraint (Series RFC-2)**

Nom. Pipe Size	WWP Rating (psi)	Thrust At Rated Pressure (lbs)	Thrust Restraint (lbs)
2"	200	628	11,400
3"	200	1,414	22,800
4"	200	2,513	22,800
6"	200	5,655	45,600
8"	200	10,053	50,600
10"	175	13,744	75,900
12"	175	19,792	75,900

# Installation Instructions

1. Clean plain end of pipe. Be sure that plain end of pipe is cut square and free of burrs.
2. Thoroughly lubricate plain end of pipe and gasket with a soap based pipe-gasket lubricant. This allows gasket to slip easily into position, making sure it seats evenly.
3. Slide flange over plain end of pipe.
4. Slide lubricated gasket over pipe end. No other gasket is necessary or should be used to seal flange faces. Slide flange forward until gasket is evenly seated in flange cavity. Hand tighten set screws against pipe surface.
5. Using conventional flange bolts, mate the Redi-Flange to the standard flange. Be sure to evenly tighten bolts alternately on opposite sides. Maintain approximately the same distance between the flange faces at all points around the joint. Tighten flange bolts to specified torque values.
6. Snug down all set screws evenly.

Tighten with wrench to torque values shown on instruction sheet provided with each flange.

## NOTES:

These instructions apply to standard wall steel (schedule 40+) and ductile iron (class 52+) pipes only. For other piping materials and special pressure or media applications, please consult us.

The design and dimensions of products and/or component parts are subject to change without notice.

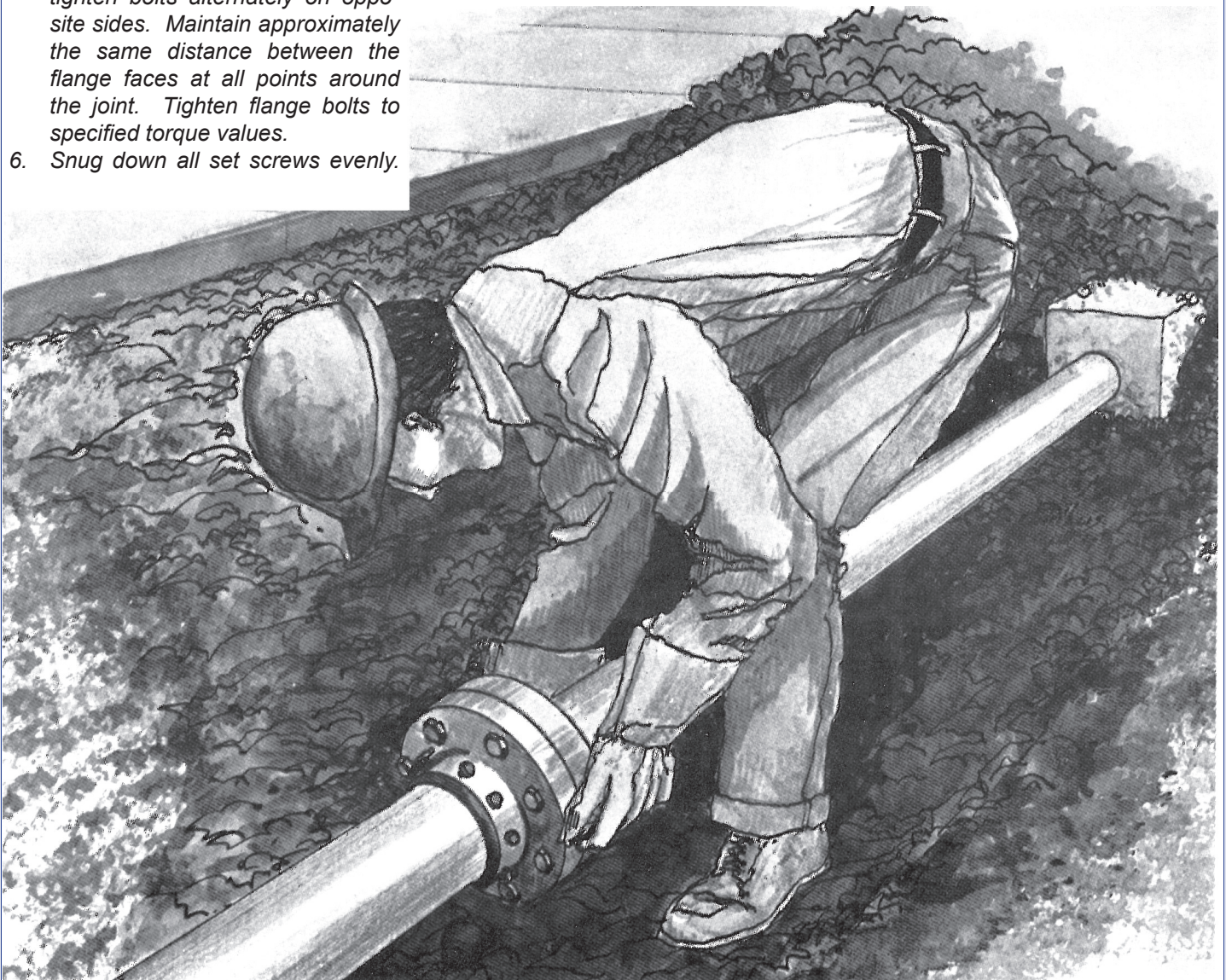
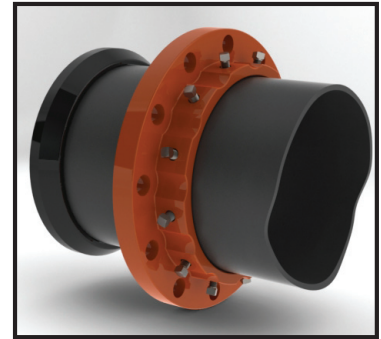

## Redi-Flange Works

The Redi-Flange™ Adapter was developed in 1975 out of what we considered necessity - the necessity to eliminate the problems inherent with pre-fabricated flanged piping. We felt there had to be a way to eliminate the numerous delays caused by inaccurate dimensional details and reliance on off-site suppliers.

The design of the Redi-Flange™ Adapter is really quite simple. We took the best features of three different products and combined them into one fitting.

The FLANGE is made of ductile iron, tougher and stronger than the conventional grey iron threaded flange; it won't break when bolts are over-tightened or from impact.

The GASKET is the standard American Water Works Association Mechanical Joint gasket. These have been in continuous service for over 60 years.

The RESTRAINT is provided by a set screw locking device, similar to that used in mechanical joint retainer glands. Thousands of these are installed throughout the world, in lieu of concrete thrust blocks and other restraining devices; the principal has been in use for over 50 years.

The Redi-Flange™ Adapter is one of the fastest growing innovations in piping. As numerous field trials by engineers proved the product not only worked, but exceeded the capabilities of threaded flanges, weld flanges, and flanged coupling adapters, the Redi-Flange™ Adapter has been accepted by most major engineering firms, water, wastewater and municipal authorities. It is UNDERWRITERS LABORATORY LISTED.

More and more engineering firms are designing total systems with the Redi-Flange™ Adapter. They've found that water, wastewater, fire protection, and process piping systems can be assembled with no delays.

There are over 200 stocking Redi-Flange™ distributors throughout the United States, Canada and the world. There is a convenient stock located near you. Call your local distributor and put the Redi-Flange™ to work for you.

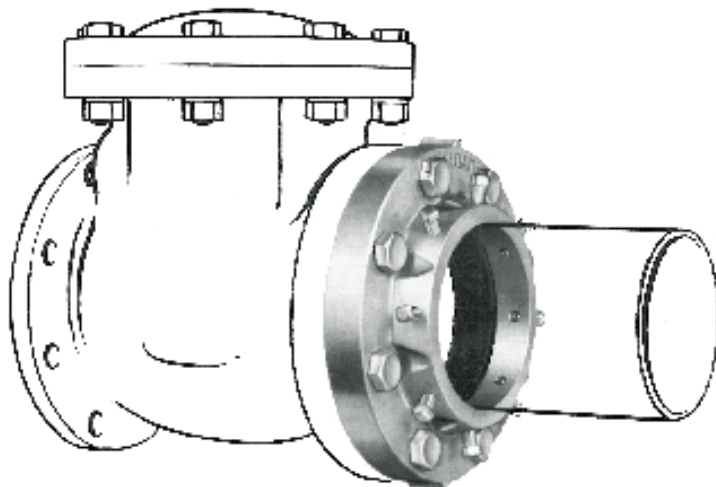

For further information and the location of the nearest stocking distributor, contact:

**UNITED** Water Products

5355 Ramona Blvd.  
Jacksonville, FL 32205  
TEL. 877-766-4459 FAX: 877-766-4458  
Website: [www.unitedwaterproducts.com](http://www.unitedwaterproducts.com)